

ÜRÜN KATALOĐU
PRODUCTS CATALOG



www.gemasa.com.tr

**GEMASA**[®]
HİDROLİK & PNÖMATİK LTD. ŞTİ.

POWERING PRECISION, ELEVATING STRENGTH



GEMASA®
HİDROLİK & PNÖMATİK LTD. ŞTİ.

www.gemasa.com.tr



Gemasa Hidrolik San. ve Tic. Ltd. Şti., krikove hidrolik sistemler imalat sektöründe uzun yıllara dayanan tecrübesiyle faaliyet göstermektedir. Güçlü mühendislik altyapımız ve yenilikçi çözümlerimizle sektördeki lider firmalar arasında yer almayı başarmış bulunuyoruz. Ürün portföyümüzde hidropnömatik krikolar, hidrolik silindirler, pnömatik hidrolik pompalar ve istifleme makineleri gibi geniş bir yelpazede çözümler sunuyoruz.

Müşterilerimizin ihtiyaçlarına en uygun çözümleri sağlamak adına sürekli olarak teknolojik gelişmeleri takip ediyor ve üretim süreçlerimizi bu doğrultuda geliştiriyoruz. Güvenilirlik, kalite ve müşteri memnuniyetini ön planda tutarak, sektördeki konumumuzu daha da ileriye taşımak için var gücümüzle çalışıyoruz.

Gemasa Hidrolik San. ve Tic. Ltd. Şti. operates in the manufacturing sector of jacks and hydraulic systems, backed by years of experience. With our strong engineering foundation and innovative solutions, we have successfully established ourselves as one of the leading companies in the industry. Our product range includes hydropneumatic jacks, hydraulic cylinders, pneumatic hydraulic pumps, and stacking machines, offering a comprehensive set of solutions.

We continuously follow technological advancements and improve our production processes to provide the most suitable solutions for our customers' needs. Prioritizing reliability, quality, and customer satisfaction, we strive to further strengthen our position in the industry.

HİDROPNÖMATİK KRİKO
HYDROPNEUMATIC JACK
GMS 110 (40-25 Ton)

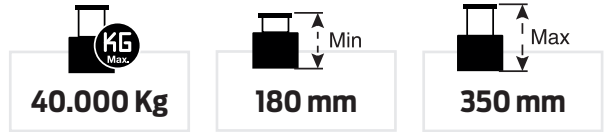
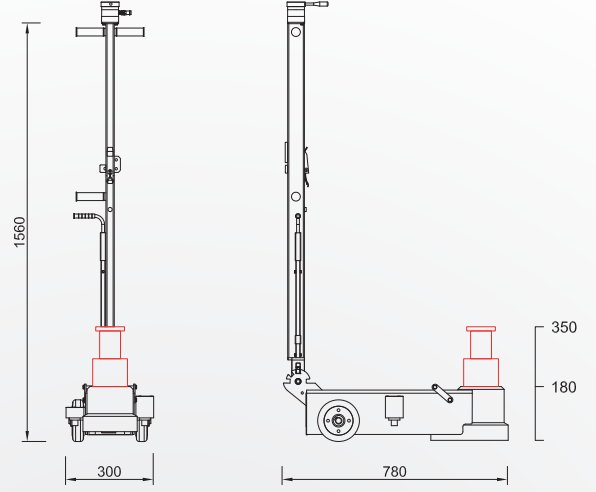

KATLANIR KOLLU MOBİL KRİKO

Kaldırma Kapasitesi Lifting Capacity	40-25 Ton
Minimum Yükseklik Minimum Height	180mm
Maksimum Yükseklik Maximum Height	350mm
Ağırlık Weight	61 Kg
Hava İhtiyacı Air Requirement	9-12 Bar

HİDROPNÖMATİK KRIKO
HYDROPNEUMATIC JACK
GMS 120 (40-25 Ton)

KG
Max
40.000 Kg

Min
210 mm

Max
440 mm

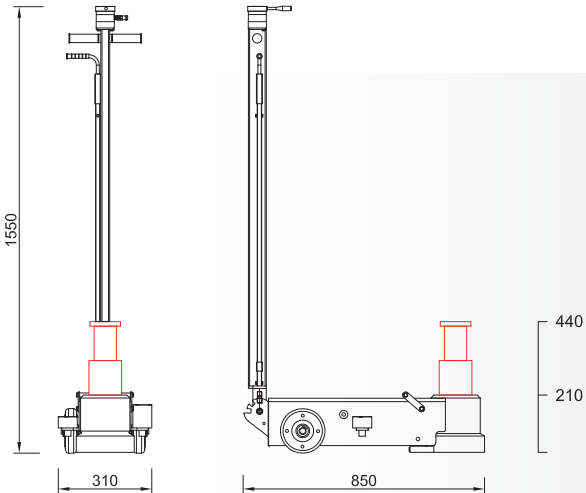

Kaldırma Kapasitesi
Lifting Capacity **40-25 Ton**

Minimum Yükseklik
Minimum Height **210mm**

Maksimum Yükseklik
Maximum Height **440mm**

Ağırlık
Weight **70 Kg**

Hava İhtiyacı
Air Requirement **9-12 Bar**

HİDROPNÖMATİK KRİKO
HYDROPNEUMATIC JACK
GMS 130 (50-25-15 Ton)

 50.000 Kg	 170 mm	 375 mm
--	--	--

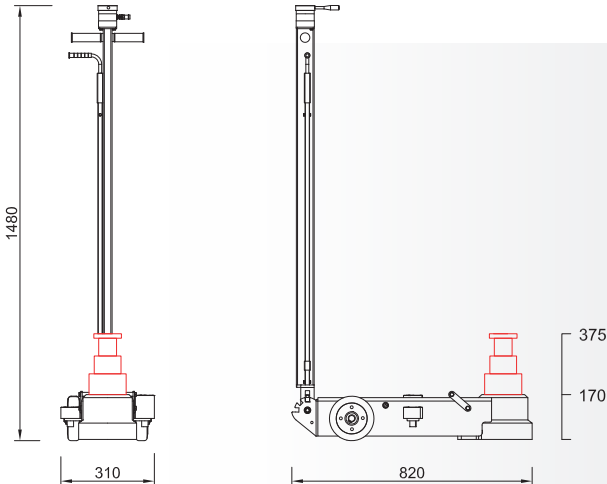

Kaldırma Kapasitesi <i>Lifting Capacity</i>	50-25-15 Ton
Minimum Yükseklik <i>Minimum Height</i>	170mm
Maksimum Yükseklik <i>Maximum Height</i>	375mm
Ağırlık <i>Weight</i>	64 Kg
Hava İhtiyacı <i>Air Requirement</i>	9-12 Bar

HİDROPNÖMATİK KRIKO
HYDROPNEUMATIC JACK
GMS 140 (50-30 Ton)

50.000 Kg

210 mm

440 mm

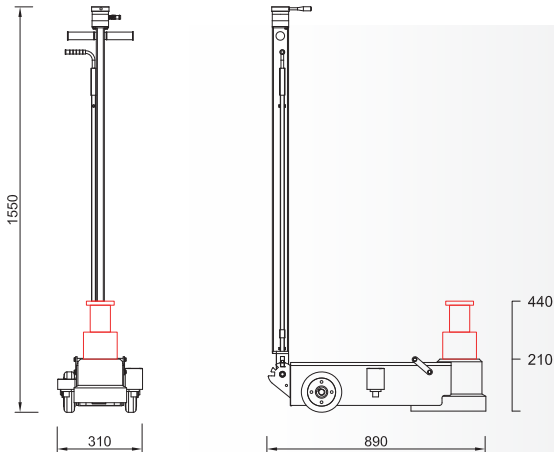

Kaldırma Kapasitesi <i>Lifting Capacity</i>	50-30 Ton
Minimum Yükseklik <i>Minimum Height</i>	210mm
Maksimum Yükseklik <i>Maximum Height</i>	440mm
Ağırlık <i>Weight</i>	78 Kg
Hava İhtiyacı <i>Air Requirement</i>	9-12 Bar

HİDROPNÖMATİK KRİKO
HYDROPNEUMATIC JACK
GMS 150 (5 Ton)

KG
Max
5.000 Kg

Min
105 mm

Max
500 mm

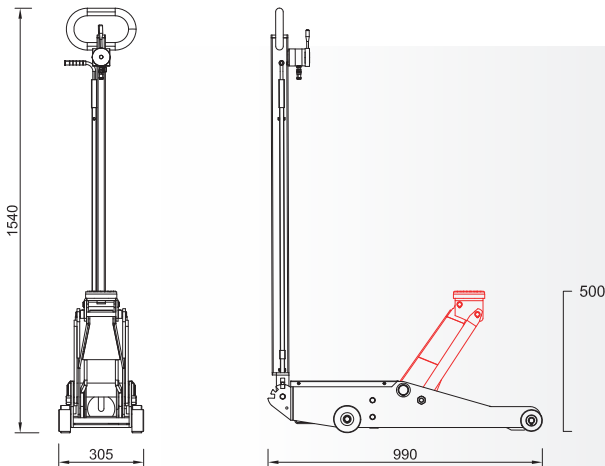

Kaldırma Kapasitesi <i>Lifting Capacity</i>	5 Ton
Minimum Yükseklik <i>Minimum Height</i>	105mm
Maksimum Yükseklik <i>Maximum Height</i>	500mm
Ağırlık <i>Weight</i>	81,5 Kg
Hava İhtiyacı <i>Air Requirement</i>	9-12 Bar

HİDROPNÖMATİK KRİKO
HYDROPNEUMATIC JACK
GMS 160 (3 Ton)

KG
Max.
3.000 Kg

Min
105 mm

Max
530 mm

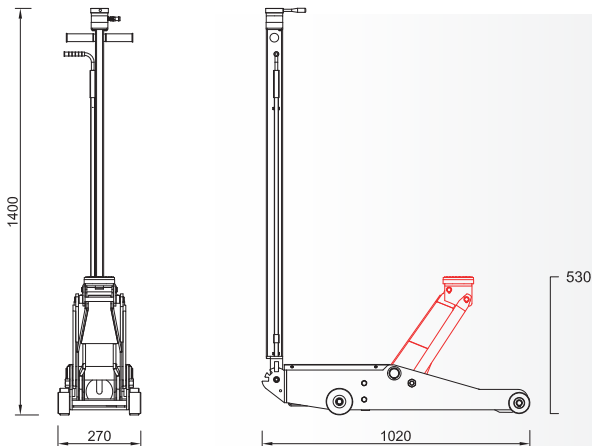

Kaldırma Kapasitesi
Lifting Capacity

3 Ton

Minimum Yükseklik
Minimum Height

105mm

Maksimum Yükseklik
Maximum Height

530mm

Ağırlık
Weight

66 Kg

Hava İhtiyacı
Air Requirement

9-12 Bar

HİDROPNÖMATİK KRİKO
HYDROPNEUMATIC JACK
GMS 170 (70-40-22 Ton)

KG
Max.
70.000 Kg

Min
180 mm

Max
425 mm

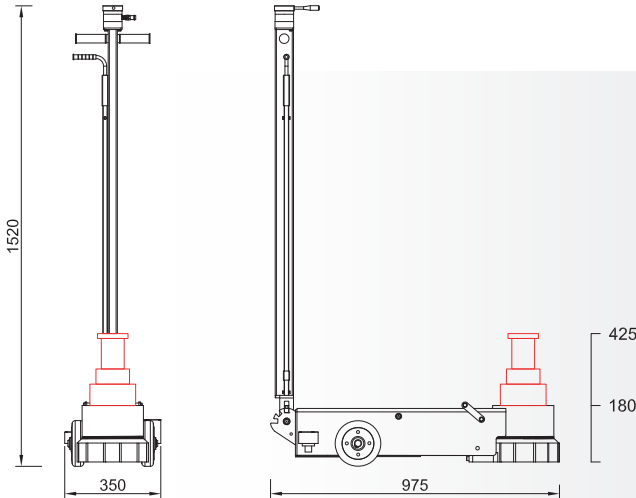

Kaldırma Kapasitesi <i>Lifting Capacity</i>	70-40-22 Ton
Minimum Yükseklik <i>Minimum Height</i>	180mm
Maksimum Yükseklik <i>Maximum Height</i>	425mm
Ağırlık <i>Weight</i>	95 Kg
Hava İhtiyacı <i>Air Requirement</i>	9-12 Bar

HİDROPNÖMATİK KRİKO
HYDROPNEUMATIC JACK
GMS 260 (40-25 Ton)

40.000 Kg

150 mm

225 mm

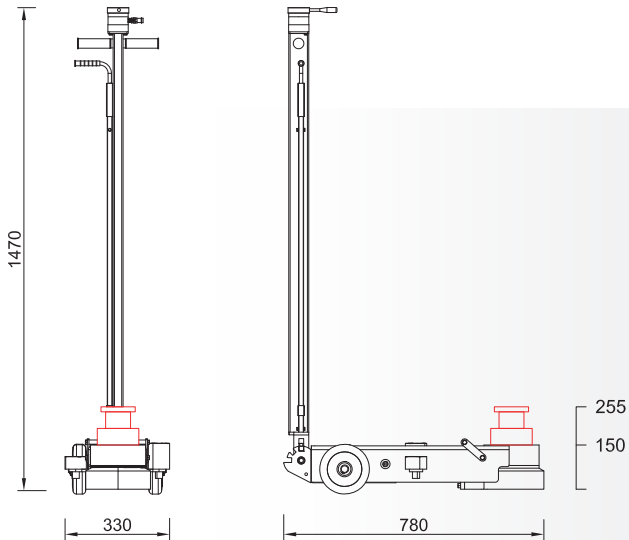

Kaldırma Kapasitesi <i>Lifting Capacity</i>	40-25 Ton
Minimum Yükseklik <i>Minimum Height</i>	150mm
Maksimum Yükseklik <i>Maximum Height</i>	255mm
Ağırlık <i>Weight</i>	56 Kg
Basınç <i>Pressure</i>	9-12 Bar

HİDROPNÖMATİK KRİKO
HYDROPNEUMATIC JACK
GMS 270 (70-40-22-12 Ton)

 70.000 Kg	 150mm	 350 mm
--	---	--

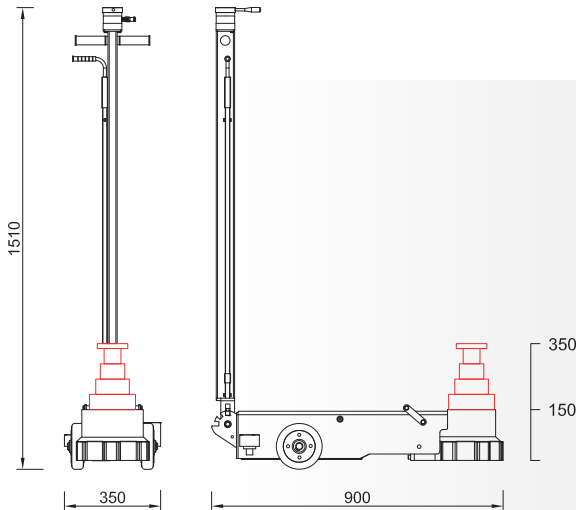

Kaldırma Kapasitesi <i>Lifting Capacity</i>	70-40-22-12 Ton
Minimum Yükseklik <i>Minimum Height</i>	150mm
Maksimum Yükseklik <i>Maximum Height</i>	350mm
Ağırlık <i>Weight</i>	85 Kg
Hava İhtiyacı <i>Air Requirement</i>	9-12 Bar

HİDROPNÖMATİK KRIKO
HYDROPNEUMATIC JACK
GMS 280 (40-20 Ton)

40.000 Kg

280 mm

620 mm

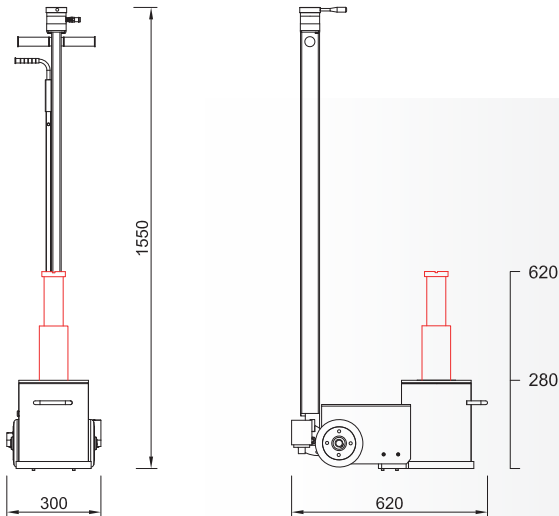

Kaldırma Kapasitesi
Lifting Capacity **40-20 Ton**

Minimum Yükseklik
Minimum Height **280mm**

Maksimum Yükseklik
Maximum Height **620mm**

Ağırlık
Weight **70 Kg**

Basınç
Pressure **9-12 Bar**

HİDROPNÖMATİK KRİKO
HYDROPNEUMATIC JACK
GMS 250 (40-20 Ton)

KG
Max.
40.000 Kg

Min
150 mm

Max
260 mm

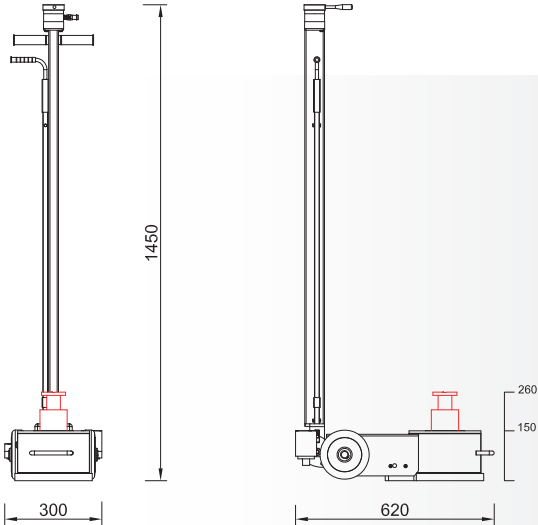

Kaldırma Kapasitesi
Lifting Capacity **40-20 Ton**

Minimum Yükseklik
Minimum Height **150mm**

Maksimum Yükseklik
Maximum Height **260mm**

Ağırlık
Weight **54 Kg**

Hava İhtiyacı
Air Requirement **9-12 Bar**

HİDROPNÖMATİK KRIKO
HYDROPNEUMATIC JACK
GMS 350 (30-15 Ton)

KG
Max.
30.000 Kg

Min
180 mm

Max
320 mm

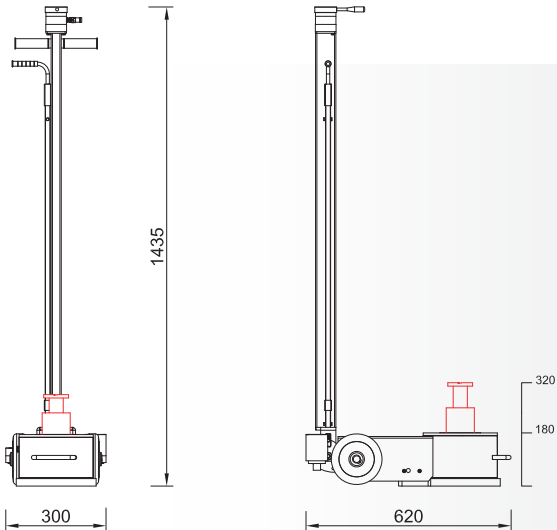

Kaldırma Kapasitesi
Lifting Capacity **30-15 Ton**

Minimum Yükseklik
Minimum Height **180 mm**

Maksimum Yükseklik
Maximum Height **320 mm**

Ağırlık
Weight **56 Kg**

Hava İhtiyacı
Air Requirement **9-12 Bar**

HİDROPNÖMATİK KRİKO
HYDROPNEUMATIC JACK
GMS 300 (50-25-15 Ton)

50.000 Kg

150mm

295 mm

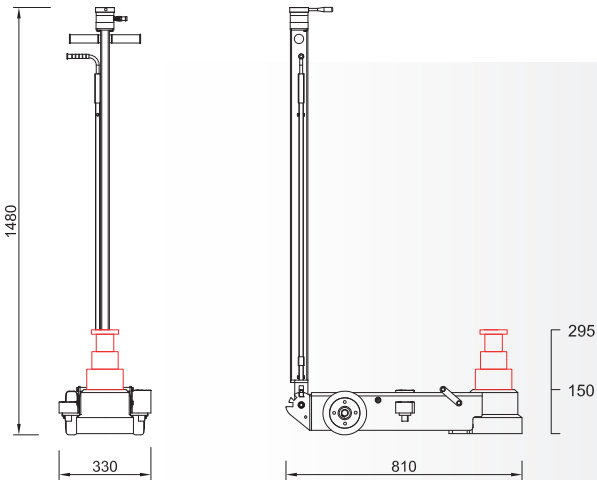

Kaldırma Kapasitesi
Lifting Capacity **50-25-15 Ton**

Minimum Yükseklik
Minimum Height **150mm**

Maksimum Yükseklik
Maximum Height **295mm**

Ağırlık
Weight **61 Kg**

Hava İhtiyacı
Air Requirement **9-12 Bar**

HİDROPNÖMATİK KRIKO
HYDROPNEUMATIC JACK
GMS 330 (70-40-22 Ton)

KG
Max.
70.000 Kg

Min
330 mm

Max
950 mm

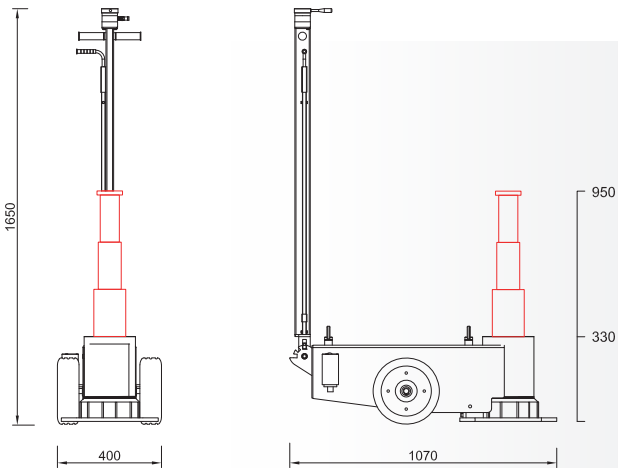

Kaldırma Kapasitesi <i>Lifting Capacity</i>	70-40-22 Ton
Minimum Yükseklik <i>Minimum Height</i>	330mm
Maksimum Yükseklik <i>Maximum Height</i>	950mm
Ağırlık <i>Weight</i>	157 Kg
Basınç <i>Pressure</i>	9-12 Bar

ELEKTRİKLİ HİDROLİK KRİKO
ELECTRICAL HYDRAULIC JACK
GMS 220 (25 Ton)



 25.000 Kg	 600 mm	 1000 mm
--	--	---

Kaldırma Kapasitesi
Lifting Capacity **25 Ton**

Minimum Yükseklik
Minimum Height **600 mm**

Maksimum Yükseklik
Maximum Height **1000 mm**

Motor Gücü
Motor Power **2,2 kW**

Pompa
Pump **6,5 Lt/dk**

HİDROPNÖMATİK KANAL KRİKOSU
SCISSOR LIFT-DOWNLOAD JACK
GMS 240



Kaldırma Kapasitesi
Lifting Capacity **15 Ton**

Strok
Stroke **500 mm**



YATAY ŞANZİMAN KRİKOSU
TRANSMISSION JACK
GMS 230 (1 Ton)

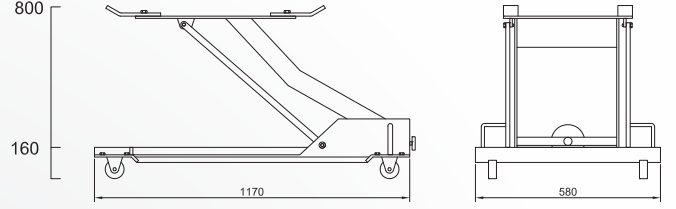

HAVA VALFİ
AIR VALVE

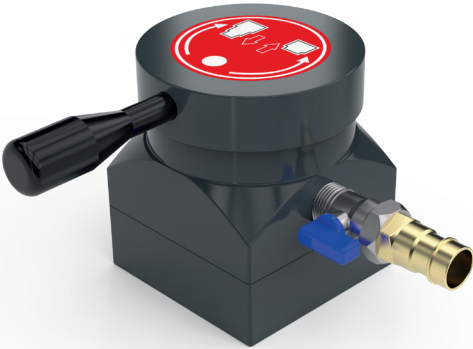

HİDROPNÖMATİK LASTİK
YANAK DÜŞÜRME KRİKOSU
HYDROPNEUMATIC TIRE SIDEBOARD
DROP JACK

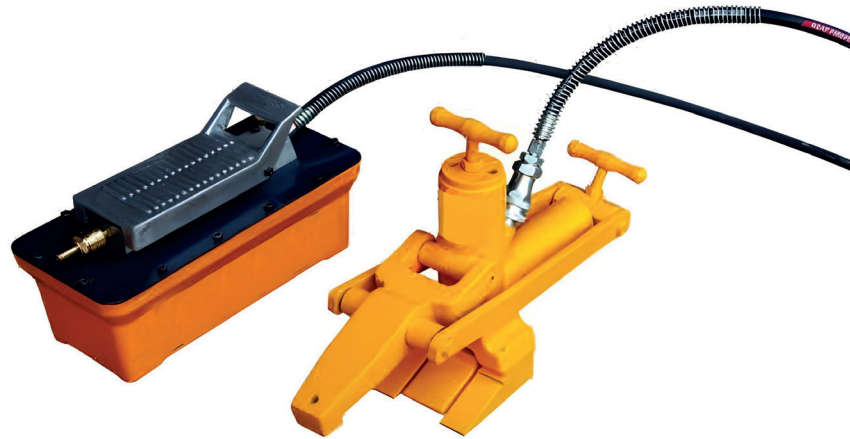

POWERING PRECISION, ELEVATING STRENGTH

GEMASA

endustriyelajans.com

GEMASA
HİDROLİK & PNÖMATİK LTD. ŞTİ.

Fevziçakmak Mah. Şehit Hamdi Karagöz Cd No:4/E Karatay/Konya
Tel: +90 332 346 43 30 • E-mail:info@gemasa.com.tr



www.gemasa.com.tr